

Qmini U-TAG 2.5

UHF-RFID miniature transponder

- passive RFID communication ISM UHF band, EPC Class1 Gen2 or ISO 18000-6C, EEPROM memory
- miniaturized TAG, size 2.5x2.5 mm
- mounting on metal or non-metal surface, useable under harsh environmental conditions
- designed for small item tagging, tool management solutions, aircraft and automotive part-tagging

This transponder device is an integral part of *microsensys* iID® system solution. This TAG operates with best performance together with *microsensys* standard RFID reader components using highly sensitive demodulators.

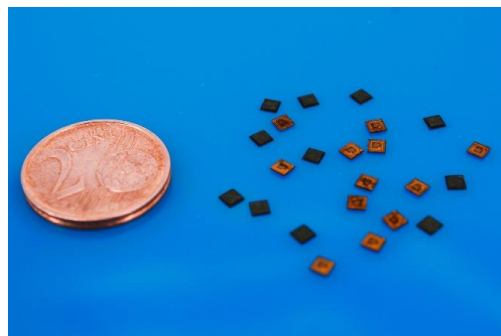

microsensys GmbH
In der Hochstedter Ecke 2
D 99098 Erfurt

TEL +49-361-59874 0
E-MAIL info@microsensys.de
FAX +49-361-59874 17
WEB www.microsensys.de

This data sheet is subject to change. Please contact *microsensys* for latest technical information. Picture may differ from original product.

Q2.5 U-TAG 010.DOCX

Contactless interface:

Chip Type / Compliance:

Carrier Frequency / Communication Rate:

Polarization:

Communication Distance:

UHF close coupling system iID®4000
NXP UCODE 8, UCODE DNA* / EPC Class 1 Gen2, ISO1800-6C
860-868MHz, 915MHz (preferably 860-868MHz)
none, inductive coupling

0 ... 25 mm, close coupling UHF communication
(depending on reader system and environmental conditions)

Memory parameters:

EPC/TID memory:

User memory:

Type:

Endurance:

128bit EPC, 96 bit TID
-
EEPROM
100000 cycles, data retention min. 20 years (T<55°C)

Sensor / security features:

Sensors:

Write protection:

Password:

Authentication:

Originality:

-
lock feature
-
-
-

Environmental:

Operating temperature:

Storage temperature:

Ingress sealing:

-25°C ... +85°C
-45°C ... +125°C (for short time +150°C), preferred room temperature
tag module, no ingress sealing

Operation:

Functions:

Measurement:

INVENTORY, READ, WRITE, (PERMA)LOCK
-

Reading:

Industrial environment:

Desktop/OEM environment:

Mobile use:

INDUSTRY 0906 UHF plus M8/M18 antenna, stationary industrial read write unit
iID® module U80
iID® POCKETwork, iID® PENsolid wireless reader with Bluetooth™ interface

Software:

iID® DEMOsoft for PC x86/x64, iID® UII writer for PC x86/x64
iID® DEMOsoft for Android

Device interface:

ISO18000-6C, EPC Class1 Gen2
iID® driver engine Windows/Android (for iID® contactless RFID interfaces)

Housing:

Packaging:

Materials:

Marking:

Mounting:

- (TAG module, pre-packaged)
Polyimid, Epoxy (black)
none, reel marking only
recommended glue: UHU plus endfest, UHU GmbH Germany

*) in development or upon request



Qmini U-TAG 2.5

iID® miniaturized transponders are useful for product identification and brand protection even for very small marking space. The tag module can be attached to metal or non-metal surfaces and needs to be packaged to be resistant against permanent environmental influences like humidity or can be integrated into objects. Please contact microsensys for full packaged transponders based on Qmini U-TAG 2.5.

Device type:	Transponder module	Unit
Mounting	Metal or non-metal surface, material injection Antenna top side	
Package	none	
Dimension	typ. 2.4mm x 2.4mm (+0.1mm)	mm
Thickness	0.41mm (+0.04mm)	mm
Delivery form:	Reel	
Product code	19.948.102.10	

Reel layout:

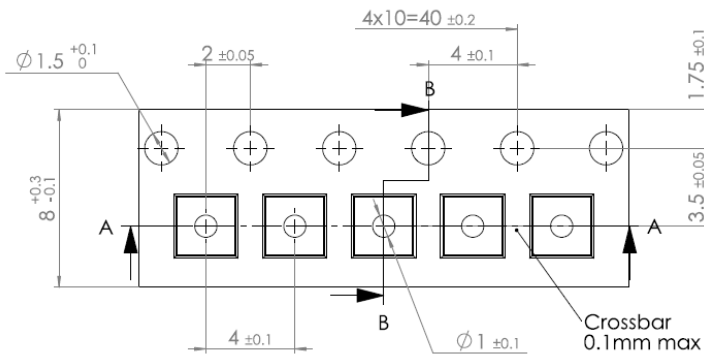

Reel - Component orientation

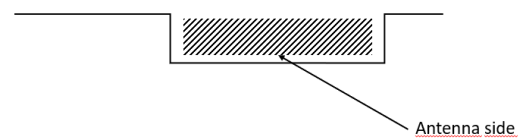

Application:

Mounting on Surface

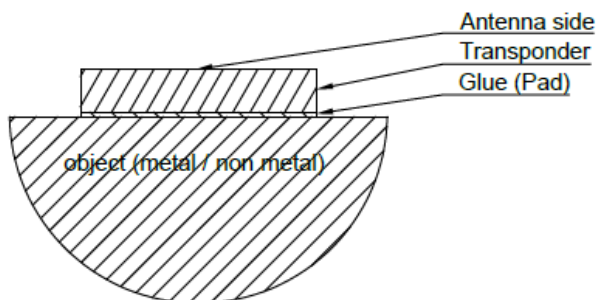

Mounting in Material

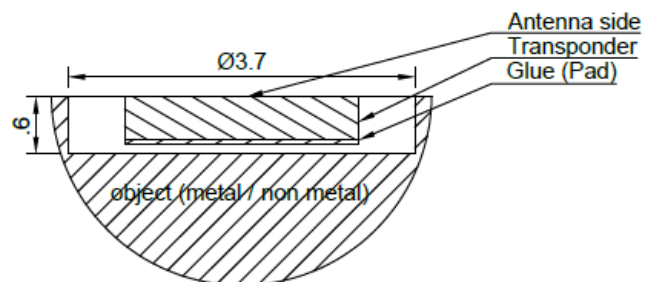

*) in development or upon request